



www.schlabs.com.ar

TAU2-A

Modelo:

0811.01

Rev doc: 00

Over temperature protector for cars

Users Manual

Warnings	Pg. 2
Electric installation	Pg. 3
Connecting cooling FAN	Pg. 3
Connecting external Relay	Pg. 4
Place of Probe	Pg. 4
Probe in water	Pg. 4
Probe in cylinder cover	Pg. 5
Functioning	Pg. 6
Set-Up	Pg. 6
Critical temperature	Pg. 7
Radiator Fan	Pg. 7
Degrees (C° or F°)	Pg. 7
Calibration	Pg. 7
Warranty	Pg. 8

Warnings

The device need 12vDC to work.



Install the device and wiring as far as possible of spark, coils, and all high voltage and noise source .



Do not wet the device, and do not use chemicals for cleaning, just a damp cloth.



Place the device and wires as far as possible of heat sources like manifold, exhaust etc.



The temperature probe have crystals, the excessive pressure or the hard work can break and avoid the warranty.



The electrical connections must be correctly isolated and soldered.



The car electrical installation must be the original, without modifications in ignition system, tuning etc.



The engine shut down require external relay.

Do not puncture, open or break, any piper or other engine part.



Do not forget add one fuse of 1A

NOTE 1: The normal operation depend of follow all observations in the present manual.

NOTE 2: SCHlabs decline all responsibility for any damage to people or things due handling of devices or wires.

Electrical Installation

The electrical wiring must be done as described on the following diagram.

The connections of Green or Yellow cables are optional.

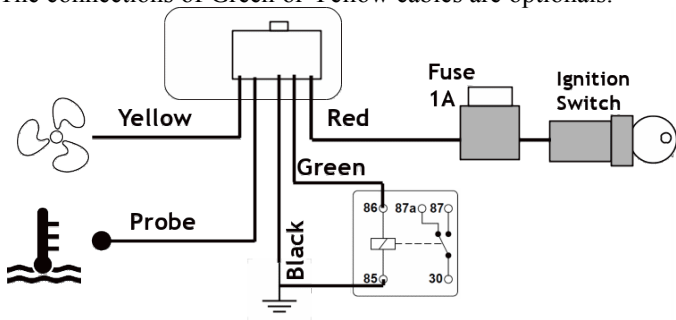

Connecting radiator Fan

Measure the voltage in the fan terminals and write it in a paper while the fan is off. And repeat the measures when the fan is on. Check with the following table and connect the yellow to the box marked on bold letter.

Example 1:

	Fan OFF	Fan ON
Cable1	12v	12v
Cable2	12v	<6V

Example 2:

	Fan OFF	Fan ON
Cable1	0v	0V
Cable2	0v	>6V

Must connect to the shadowed cable.

Shutdown Relay Connection

The shutdown connection is optional. If you want do there are many ways to stop an engine. But the installator must be careful with:

- The driver don't loose the breaks
- The driver don't loose steering.
- The driver don't loose the vehicle control.

One good choice is cut the fuel flow.

Probe Placement

There are 2 ways to use the temperature probe:

- 1)Reading the water
- 2)Reading the cylinder cover.

Reading the water

Measuring water is the way chosen by manufacturers to read the temperature of an engine. However when there is a break in a hose or radiator, it can not always be seen before great damage.

If you choose this way follow the next cautions:

- DO NOT OPEN THE COOLANT CIRCUIT (this will break the pressurization)
- DO NOT remove any original sensor of the car.
- Touch the probe with one place of high water flow.
- Avoid that the probe be cooled by the wind.

-The probe is of crystal, do not apply high pressure, do not hit, and do not squeeze.

One way to do it is to support it against a hose and fix it with 5 or 6 laps of cloth insulation tape. The tape will prevent air from leaking, it will retain it and, being of fabric, it will not stretch. Also can use other fixation methods with moderated pressure.

Reading on cylinder cover

If it is well measured it is the ideal way to save the engine. However, it depends a lot on the location of the probe, since it can be affected by the heat of the exhaust pipe, by the frontal winds and other circumstances, that's why it is only recommended to be installed by experts. In addition to having different variations to which one is accustomed to see.

If you choose this way follow the next cautions:

-Touch with the probe any place against any place where the temperature of cover reach the probe.

-Some peoples do a hole in the cover, this only can do people that know the cover in both sides to ensure. (really expert)

-Avoid that the probe be cooled by the wind.

-The probe is of crystal, do not apply high pressure, do not hit, and do not squeeze.

-Do not remove covers, gaskets or the cover screws.

One way to do is find one screw that fix some sensor, close to the cylinder cup fix with an aluminium.

Working

The TAU2 read the temperature of engine in a range of 0~123°C o 30~255°F.

When the temperature exceed the critical setting start the screen start blinking, and start a warning sound (One beep for each degree in excess). In this way the noise will be more annoying with more temperature excess.

If you press the middle button the sound will be muted. This will remain until temperature go down. The mute do not block the engine shutdown.

When the over temperature exceed 6 degrees, the red LED will turn on, and the shutdown signal will be send, and the sound continue in 6 beeps. If is in mute only the shutdown signal will be send.

If at start of the engine the temperature is high, the system do not do any sound or shutdown until temperature down.

When the radiator fan is on, one led blue will be turned on.

Setting up

Press the middle button by 3 seconds to enter into setup menu:



Set = Entering in setup
-01 = Version product



Use the upper and lower switch's to choose the parameter that you want change and press the middle to edit the value.

Change the value with upper and lower key and when finish press the middle button.



Critical Temp: Select the temp taking care of:

1-If the temp is set 97, the alarm start in 98

2-If the temperature is set to 97, the shutdown is

in 104 degrees.



Fan:

0=If with fan off there are 12v in the cable

1=If with fan off there are 0V in the cable



Grades scale:

0=Show in centigrades

1=Show in fahrenheit



DO NOT TOUCH !! Change this value alter the measurement.

To calibrate you should boil water and make sure that you mark 100c(212f) while the water

is boiling. The ambient temperature is not so important.



FIN: Save the new values and return to normal operation when press the middle button.

Warranty Certificate

- General rules of the guarantee

SCHlabs, guarantees the good and correct functioning of this product.

The guarantee will be recognized for a period of 3 (three) months from the purchase, the defects of construction and materials being covered.

If, during the guarantee period, the product is defective, SCHlabs will take charge of the repairs or substitutions required by the product. They will be made at the SCHlabs facilities and the shipping costs will be borne by the customer.

For accessories or components that have not been manufactured by SCHlabs, only the guarantees of the respective producers are valid.

This guarantee is the only one given by SCHlabs, so any other is excluded.

- Terms

The guarantee will only be recognized with the presentation of this certificate with date and stamp of the reseller, or in its absence with the purchase invoice. This guarantee will be valid only for those who are in good standing with the payments.

- Warranty exclusions

1.- Periodic checks, maintenance, repairs or replacement of parts due to normal deterioration.

2.- Malfunction due to negligence, improper use or improper installation not in accordance with the given technical instructions and any defect that was not produced due to construction defects.

3.- Products installed, modified, repaired, replaced, assembled or maneuvered by people who do not have written authorization from SCHlabs

4.- Accidents due to force majeure or other causes (water, fire, lightning, electromagnetic fields, etc.) that do not depend on SCHlabs.

Read about others SCHlabs products

HRR2: Stepper, injector and IAC tester

HMP1: Throttle and sensors tester

GNC2: CNG digital switch

SCHlabs

Tel: 54 11 4639-5945

<http://www.schlabs.com.ar>

El araucano 1389 Cap Fed - Argentina.